

Site preparation guide

AT&T Virtual Private Network

AT&T Virtual Private Network Express

AT&T Ethernet Private Line Service-Wide Area
Network-Global

AT&T Internet Aggregation

Site preparation guide: Customer and Site contact responsibilities

Customer responsibilities

- Ensuring your site contact is knowledgeable and on-site to meet with AT&T or other access provider technician as required.
- Making sure to obtain important contact information for everyone for future reference.
- Disclosing any noise or time restrictions; building access parking, loading zones, elevators concerns; work area concerns such as asbestos, hazardous materials, etc.
- Overseeing the site build out and confirming the completion dates to AT&T.
- Keeping both your AT&T Service Delivery Team and access provider informed on the progress of your site readiness and completion.
- If a site survey is requested or required (additional fees may apply), ensuring your site contact is aware and available and on-site during the survey.

For managed options:

- Ensuring that a signal strength test has been performed to determine eligibility of wireless out-of-band.
- Providing analogue telephone line, if you are using POTS out-of-band. For more details: [See page 9](#)

Site contact responsibilities

- Working with AT&T and access provider to schedule building access and resolve any issues, as needed.
- Obtaining building access and being familiar with the telecom rooms.
- Acting as a liaison and advocate when working with the building owner or manager.
- Showing access provider technician where to install the equipment for access circuit (demarc). The demarc is the location inside the building where AT&T's service terminates from the street.
- Showing AT&T technician where the circuit demarc is located and where to install the AT&T provided equipment, if any.
- For multi-tenant buildings, working with the property manager or building owner to determine the location of your company's demarc, which may or may not be collocated with existing copper or fiber facilities.
- Providing adequate safe working space, a clear path and easy access to the backboard, jack, land line, power outlets and the equipment.
- Providing inside wiring if the building's demarc is not in your office location or on a different floor than the equipment.

Site preparation guide: Preparing your site for installation

Access provider site survey

- If a site survey is scheduled, contact is expected to meet with the access provider technician to walk through what will need to be completed before we can install the service.
- We recommend to take notes and keep the name and contact information of the access provider technician in case you have questions later.
- We will keep site contact notified of any delays on our end, such as special installation, or facility delays.
- In certain instances, special installation may be required due to lack of facilities. In these cases, your AT&T Service Delivery Team will contact you with additional information and instructions.

Site preparation

- AT&T negotiates a project schedule with all parties to enable service completion as close to your desired date as possible.
- You are responsible for completing the site preparation work or hiring someone to complete the work on your behalf.
- Please address and complete as soon as possible the site preparation and any site survey(s) scheduled to help avoid installation delays. This includes any electrical requirements, the backboard for the network equipment and applicable extended inside wire.
- There are typically 5 basic areas that are your responsibility to facilitate equipment installation and delivery of service – path; space; rack and environmental; grounding and power, which are outlined within this guide.

AT&T VPN implementation guide is available on [Business Center](#)

(Provide your username and password)

For a quick tutorial on preparing your site for installation, see the AT&T How to video series: Site Readiness for Fiber Technology Installation: [here](#)

Site delayed or not ready

- Please keep your AT&T Service Delivery Team and access provider technician informed of your progress and notify them with a site completion date, which must be minimally 15-days prior to your service scheduled due date.
- Access provider technician may elect to revisit your site to verify the work has been completed or if it has been determined that additional work may be required.
- Any changes to plans or any delays associated with site preparation can have a corresponding impact to the service delivery date.
- Please contact your AT&T Service Delivery Team and your account team representative if delays are anticipated so work forces can be rescheduled.
- There may be billing implications if the site is not ready in time.

Site preparation guide: Site requirements

Access provider technician consultation

For Ethernet and non-Ethernet Access sites (US and International)

- Access provider technician, whether from AT&T or another vendor, may conduct a site survey with the assistance of your site contact. For more details: [See page 3](#)
- Items on this page are a list of general requirements associated with installation of fiber optic-based service.
- Access provider technician may identify and inform you of any site-specific work and/or additional requirements you may need to execute for your installation.

For Ethernet Access sites (US only)

- If you are eligible for the entrance facility offer*, we will complete the pull box; wall mounted backboard; and power on your behalf, after you sign a systems permissions form.

Path

Outside conduit specifications (Property line to your building)

- Minimum 2"/5cm, recommended 4"/10cm conduit with pull rope to point-of-entrance.
- Minimum 3'/90cm sweeping radius.

Inside Conduit Specifications (Demarc to router)

- Clear path with conduit or cable tray from building entrance to demarc point.
- Minimum 2"/5cm EMT type conduit with hard plastic corrugated inner duct with pull rope.

Pull box requirement

- Less than 3'/90cm sweeping radius. No more than 3 x 90o turns. No right angles.
- Path is no longer than 300'/91m.
- Dimensions for pull box – 12" x 12" x 18" / 30cm x 30cm x 46cm.

Additional inside wiring

- Inside wiring, unless otherwise noted for managed options, is your responsibility.
- You can do it yourself, hire AT&T (in some US states) or a vendor.

Power

Power / Electrical specifications

- AC power outlet on a dedicated fused breaker rated min. 15 amps OR Nominal voltage, 48VDC, +24/-24 VDC, 110V, 125V, 220v or 240v.
- Must be located within 6'/1,8m of the equipment.

Environmental

Wall mounted backboard / relay rack

- 4'x4'x3/4"/1,2m x 1,2m x 2cm Fire retardant plywood mounted to studs with screws.
- 40o – 85oF/5o – 30oC at 0% – 85% humidity for Ethernet.
- 40o – 100oF/5o – 37oC at 20% – 50% humidity for ≥DS3.

Site preparation guide: Space requirements

Floor space and environmental requirements

- Must meet regional specifications dictated by local regulatory agencies, as well as be clean, environmentally conditioned and have proper lighting. If AT&T equipment is provided, space must be secure, including locks on doors.
- Equipment location should be decided prior to placing your order and not be changed later, to avoid installation delays.
- Space must include 3'/90cm clearance around equipment and floor must withstand between 750lbs / 340kilos (without batteries) to 1,100lbs / 499kilos (with batteries).
- Standard installation, fiber transport equipment is placed in common area with access to entire building. Site contact must obtain necessary permissions.
- Wall mounted installation is recommended based on small size of most network terminating equipment, though you may opt for floor rack mount if preferred. For examples of wall mount diagrams: [See page 6](#)
- Cabinet installations require that if the floor is raised, that there be no obstructions below the floor tiles and a small section of tile must be cut to allow for cable entry. See example cabinet equipment footprint requirements.
- Rack must be of suitable strength and quality for site's earthquake risk factor and be able to support the intended equipment weight and must meet minimum standards for secure operation.
- If equipment is placed in center of terminal room, an overhead ladder racking or under floor cable tray from the wall to fiber equipment is required.

Example cabinet equipment footprint requirements

CABINET FOOTPRINT

Requires approximately:

- 1'/30cm clearance on top for fan
- exhaust
- 3'/90cm clearance from power



7' / 2,1m RELAYRACK FOOTPRINT

Requires approximately:

- 3'/90cm for front to rear access
- 1'/30cm clearance on top for fan
- exhaust
- 3'/90cm clearance from power

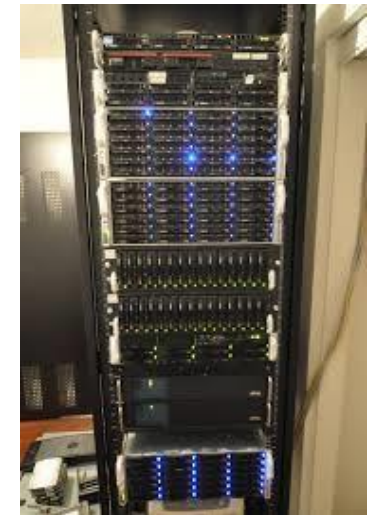

Site preparation guide: Wall mount diagrams

Wall mount diagram - Fiber

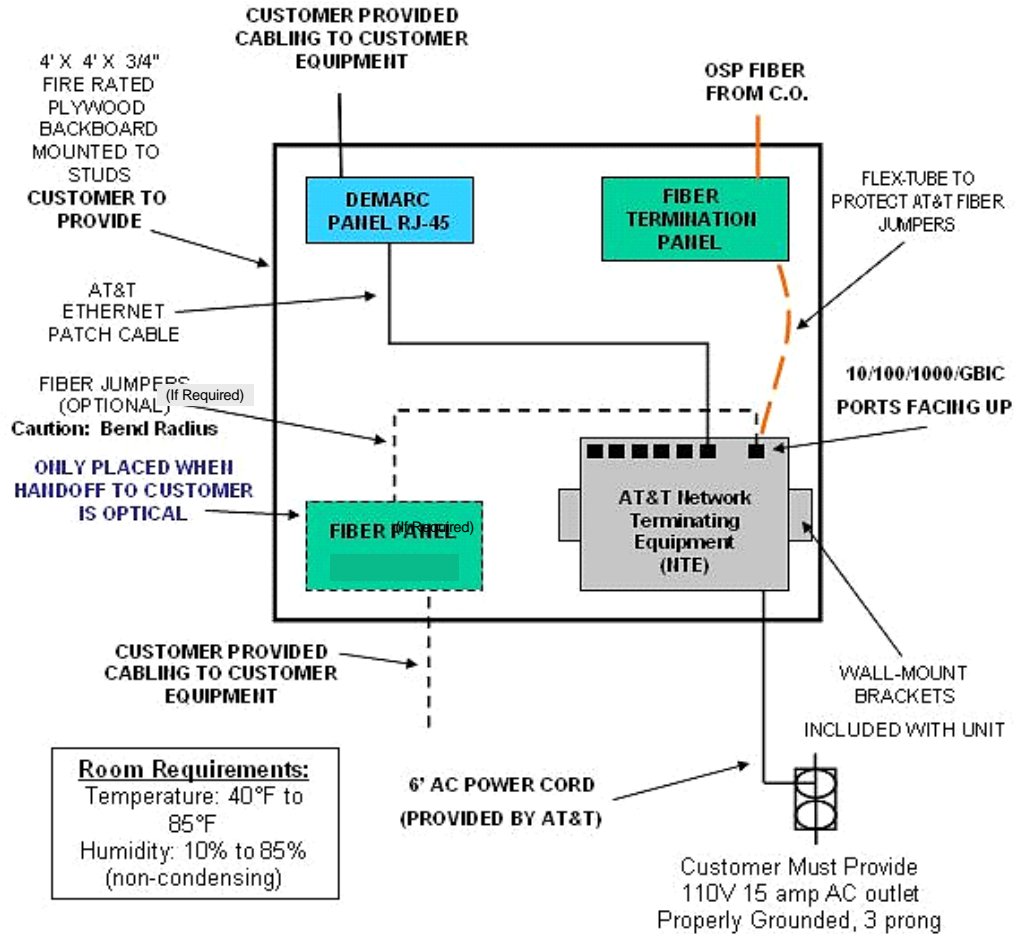

Wall mount diagram - Copper

Wall Mount Diagram – Copper:

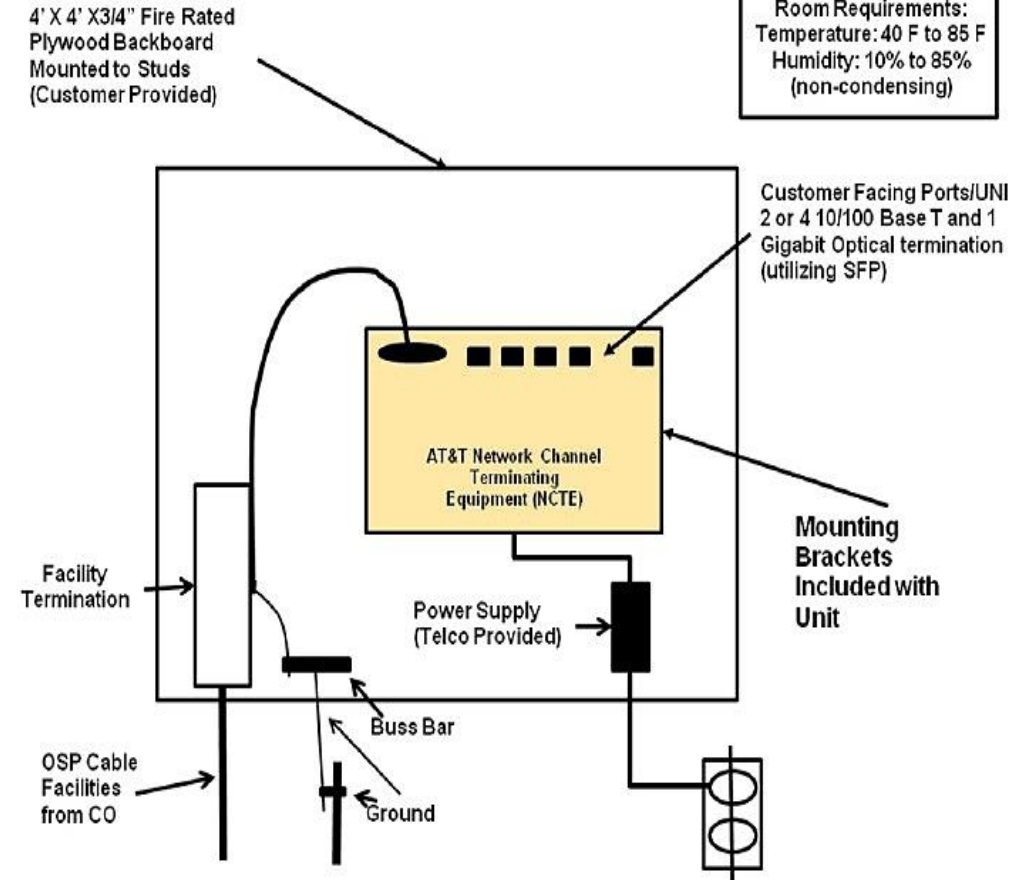

Site preparation guide: Rack requirements

Rack quality / installation for multiple AT&T services

AT&T supports your need to maximize your floor / rack space. For requests to deploy equipment for multiple AT&T services within same rack, the following applies:

- Minimum of 3'/90cm space in front and rear of rack, per building code requirements.
- Aluminum racks require stiffening plates made up of a 12"/30cm minimum tall blank plate secured to the frame to strengthen it, with the stiffening plate located mid-height.
- Minimum opening for 19"/48cm rack is 17.8"/45cm to allow for 19"/48cm EIA width for equipment to be mounted in rack.
- Rack must be securely mounted and braced by bolts to building floor (raised access floor panel is not building floor). Rack is secured to adjacent frame in lineup to prevent impact between frames.
- Minimum standards for quality are sufficient to bear expected weight of equipment, including bracing shelves.
- Equipment should be placed in the lower half of frame with heaviest being the lowest.
- All mounting hardware is to be provided by customer.
- Cable supporting structure must meet the US National Electric Code Standards and/or your local regulatory and may be either a cable rack or metallic EMT conduit. For door installations, this may include, but not limited to, a cable rack, backboard and any required conduit. For outdoor installations, installation could include, but not limited to, a H-frame, pole, wall space and any required conduit.
- For fiber facilities, the equipment comes with connectors that handle rigid conduit between $\frac{3}{4}$ to $1\frac{1}{4}$ " / 2 to 3cm in diameter, but $1\frac{1}{4}$ " / 3cm flexible non-metallic conduit may also be used.
- For copper facilities, the equipment comes with connections that handle rigid conduit between $\frac{3}{4}$ to 1" / 2 to 2,5cm, but 1" / 2,5cm liquid-tight flexible non-metallic conduit may also be used.
- For conduit that does not meet identified specifications, you must provide all required connectors.
- Access circuit equipment varies by vendor, but the footprint and floor space requirements are approximately the same. Higher speed equipment may require more than one bay or cabinet and has different power requirements.

Site preparation guide: Grounding & Power requirements

Grounding

Grounding the any equipment is your responsibility, we encourage you to consult your electrical contactor.

- All equipment necessary for the service, including the router, relay racks and cabinets must be grounded by placing an exposed #6 / 14mm² or larger copper grounding wire to the building's ground source.
- The ground wire needs to be attached to the closest ground rod (earth ground) or building bus bar available and run to your network terminating equipment location.
- All equipment requires a properly grounded 110v, 220v or 240v (dependent upon in- country standards), 15 amp, 3-prong AC outlet.

Not properly grounding your equipment will result in potential service degradation in quality and maintenance issues

Centralized Bulk Power Plant

If you are utilizing a stand-alone, centralized bulk power plant, required grounding:

- A #2 / 35mm² stranded copper ground is required from your earth electrode system to the equipment room. It should be connected to a grounding bus bar or otherwise directly connected to different components
- A #6 / 14mm² stranded copper ground is required from the grounding bus bar to the network terminating equipment

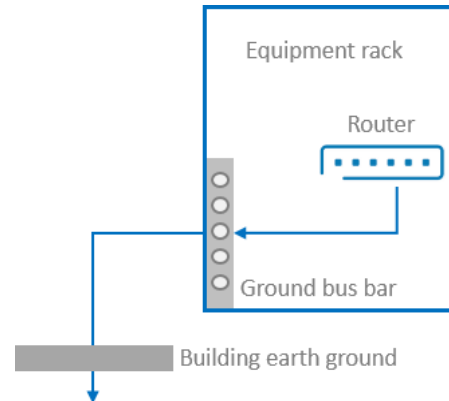

Embedded / Integrated Power

If you are using an embedded or integrated power configuration where the power plant is located within the same rack or cabinet as the equipment it powers, requiring grounding:

- A #6 / 14mm² stranded copper ground is required from your earth electrode system to the equipment room. This would be connected to a grounding bus bar or otherwise directly connected to different components
- A #6 / 14mm² stranded copper ground is required from the grounding bus bar to the network terminating equipment
- Specific requirements may also be discussed with the access provider technician or AT&T field technician at the time of the site survey visit (US only)

Site preparation guide: Router installation & Managed site requirements

Router installation & configuration

Managing your own router

You are responsible for installing and configuring your router, including connecting it to the access circuit demarcation point.

AT&T VPN managed option

We configure, ship and install the AT&T owned equipment, including testing and monitoring of service connectivity.

AT&T VPN managed customer self installation option (US only)

We configure and ship the AT&T owned equipment to you and provide an implementation planner with installation instructions.

Note: If you ordered IP Flexible Reach, your router configuration must include a static route to enable VQM (Voice Quality Manager) support. Directions are in the Voice over IP Customer Configuration Guide.

Managed site requirements

Out-of-band requirement

An “Out of Band” (OOB) connection is required by AT&T Managed Services to complete initial installation, provide timely lifecycle support, level 1 problem determination, diagnosis, and break- fix. It can also be used to support certain MACDs.

The OOB connection is never used for transmitting customer data. It is only used by AT&T when needed and is a requirement for SLAs as defined in the applicable AT&T Business Service Guide.

Out-Of-Band Options

Standard options include

- Wireless using an AT&T provided SIM
- Wireless using a Customer provided 3rd party SIM
- Broadband using a Customer provided broadband connection
- Plain Old Telephone Service (POTS) using a Customer provided telephone line. (shared or dedicated)

*Not all options are available in all countries

Wireless OOB

Wireless requirements

The preferred option is Wireless OOB with AT&T provided wireless modem and AT&T provided SIM. Consult your sales representative to evaluate wireless OOB eligibility for your site prior placing your order. Sales will guide you through the process of performing the signal strength testing on your site.

If the signal strength is inadequate at the time of installation, the service activation of your order will be delayed. Subsequent change order will also be required to replace the wireless modem with an alternative option (broadband or POTS).



AT&T Business